

DED-TYPE FASTENER STANDARD PROTRUDED-TYPE FASTENER STANDARD PROTRUDED-TYPE FAS

From pre-fabricated buildings to space applications, no fastener offers the ease of use, strength and unprecedented performance of Zahodiakin fasteners. *These positive-locking fasteners are the most rapidly-threading fastener on the market. This makes them ideal for applications requiring quick and convenient access to panel areas without sacrificing the strength of the connection.

The Zahodiakin fasteners unique foolproof design is characterized by its ability to synchronize the fastener stud with its receptacle. Misalignments are automatically corrected and there's never a cross-threading. Just place the two parts together, push, and give a half-turn with a screwdriver to complete a positive-locking, high-strength connection. In seconds.

Initially designed to secure access doors, panels and structural components under the most critical aerospace conditions. Today, both commercial and military fastener products are available, with the military line designed to meet or exceed Mil-F-22978A (ASG) (NASA22978).

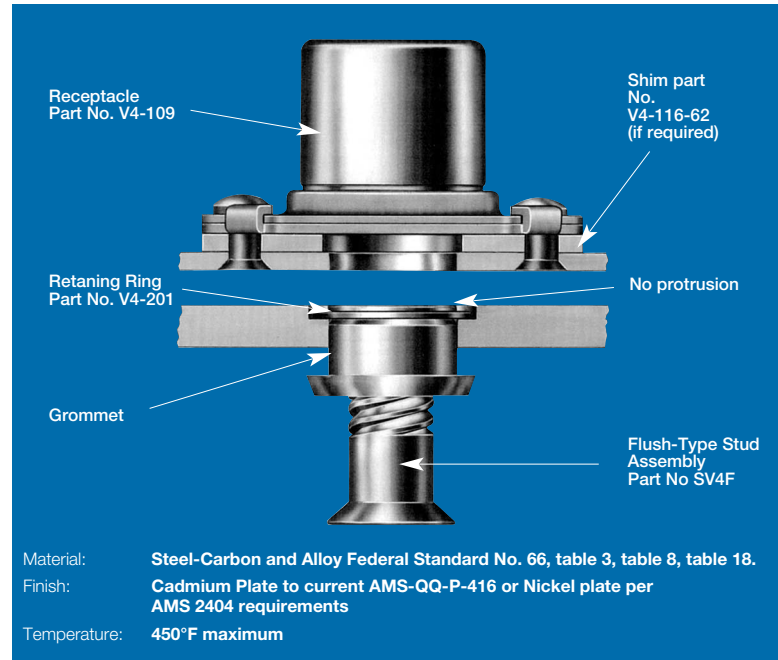

High-Performance Comparative Test & Performance Data

Mechanical Properties	MIL-F-22978A	Measured Performance
Locking Torque (lbs)	30 Max	30 Max
Unlocking Torque (lbs)	35 Max	35 Max
Torque Out (lbs)	100 Min	100 Max
Ultimate Shear Load (lbs)	4650	8300
Rated Shear Load (lbs)	3560	4500
Ultimate Tensile Load (lbs)	2210	4500
rated Tensile Load (lbs)	1700	1700
Sheet Separation @	.015	.013 1700 lbs(ins)
Sheet Pull-up (in)	1/16	1/16
Stud Push-out (lbs)	150 min	200 min
Receptacle Pus-Out (lbs)	125min	130min
Vibration Requirements	Para 4.6.8	Exceed Spec.
Misalignment Float (in)	=.020	±.020
Elevated Temperature Limit (°F)	450	450
Corrosion resistance (hours)	96	200

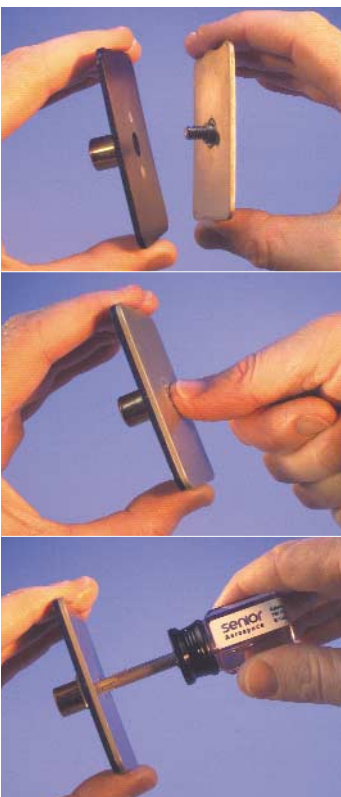

1. Align stud threads with receptacle. Unique synchronizing-ring design automatically corrects misalignments.

2. Push threaded stud firmly into receptacle.

3. A half-turn with a screwdriver completes positive-locking connection. Total time: a few seconds.

DED-TYPE FASTENER STANDARD PROTRUDED-TYPE FASTENER STANDARD PROTRUDED-TYPE FAS

TO ORDER

Order by part number and description, Stud Assembly SV4F - (Stud number), Receptacle Assembly V4-109, Retaining Ring V4-201 and Shim V4-116-62.

Part Number	Weight (lbs)	Part Number	Weight (lbs)	Part Number	Grip Range	Total Weight (lbs)	Part Number	Weight (lbs)	Grommet Length			
Ketema Stud ① Assy.	Ketema Retainer Ring	MS Stud Assy.	Stud Assy.	Ketema Receptacle	MS Receptacle Assy.	Receptacle Assy.	MS ② Fastener Assy	T₁ + T₂	Fastener Assy.	Shim (if required)	Shim	Total Length ± .010
SV4P-1	V4-201	MS 17732-1A	.012	V4-109	MS17732-21	.028	MS 17732-1	.116 - .185	.040	V4-116-62	.0026	.200
SVAP-2	V4-201	MS 17732-2A	.012	V4-109	MS17732-21	.028	MS 17732-2	.143 - .255	.040	NOT REQUIRED (if part number V4-116-62 9 (shim) is used, deduct .062 from min and max. grip range dimension)		.200
SVAP-3	V4-201	MS 17732-3A	.014	V4-109	MS17732-21	.028	MS 17732-3	.256 - .325	.042		.275	
SVAP-4	V4-201	MS 17732-4A	.016	V4-109	MS17732-21	.028	MS 17732-4	.326 - .395	.044		.350	
SVAP-5	V4-201	MS 17732-5A	.018	V4-109	MS17732-21	.028	MS 17732-5	.396 - .465	.046		.425	
SVAP-6	V4-201	MS 17732-6A	.021	V4-109	MS17732-21	.028	MS 17732-6	.466 - .535	.049		.500	
SVAP-7	V4-201	MS 17732-7A	.023	V4-109	MS17732-21	.028	MS17732-7	.536 - .605	.051		.575	
SVAP-8	V4-201	MS 17732-8A	.025	V4-109	MS17732-21	.028	MS 17732-8	.606 - .675	.053		.650	
SVAP-9	V4-201	MS 17732-9A	.026	V4-109	MS17732-21	.028	MS 17732-9	.676 - .745	.054		.725	

MS ① Stud, grommet and retainer ring

MS ② Stud, grommet, retainer ring and receptacle

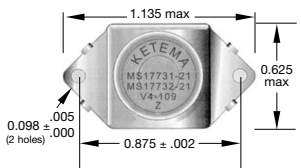

Code

T₁ = Outer Panel

T₂ = Inner Panel

L = Length of Grommet

(see table)

L₁ = Length of Grommet Under

Head = (L-.094)

P = Engagement of Grommet in Panel

T₂ = (L₁-T₁)

Formula

When P is greater than T₁, c' bore sheet T₂

When P is less than T₁, c' bore sheet T₁

Example No.1

T₁ + T₂ = .140 (T₂ = .090, T₁ = .050)

L₁ = (L-.094) = (.200-.094) = .106

P = (L₁-T₁) + (.106-.050) = .056

In this case P is less than T₁; therefore, c' Bore T₂.

Example No.2

T₁ + T₂ = .275 (T₂ = .150, T₁ = .125)

L₁ = (L-.094) = (.275-.094) = .181

P = (L₁-T₁) + (.181-.125) = .056

In this case P is less than T₁; therefore, c' Bore T₁.

Grip Range = T₁ + T₂ + .094

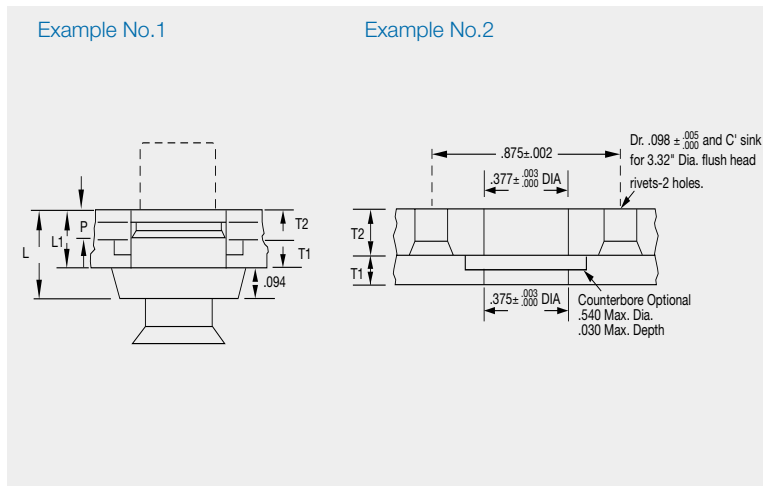
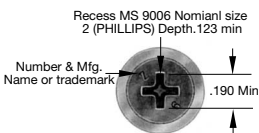
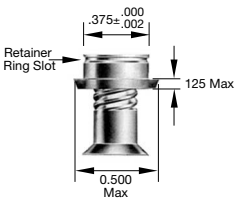
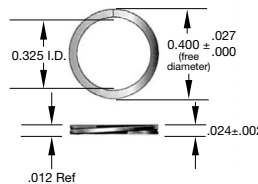
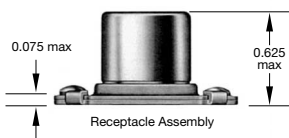

Notes:

1. Float of receptacle shall not be less than .020 in any direction from the center position.
2. Dimensioning and gaging of the above recess shall be in accordance with Military Standard Drawing MS 9006, Cross Recess and Gage Dimensions.
3. If Part No.V4-116-62 (Shim) is used, deduct 0.062 from both the minimum grip range dimensions.

senior
Aerospace

Ketema
790 Greenfield Drive
El Cajon
California 92021
Tel. : +1 619 442 3451
Fax : +1 619 449 1456
E-mail: marketing@sfketema.com
www.senioraerospace.com/ketema